



9108 Series

EMERGENCY EXIT SIGN



General Description

Decorative & seek self contained LED exit luminaire, suitable for hotels & shopping mall, where the emergency lights must blend with the architectural design.

All models of 9108 series luminaires will maintain the same lux output during the entire emergency mode operation as specified (only the battery being used to power the lamp and fitting controls). This is achieved as our luminaires are working with "constant current" technology. The same current output is maintained even if the battery voltage goes down. The luminaire lamp current is totally cut off when the battery voltage falls below a certain pre-determined voltage. Leaving enough charge to power the control module.

9108 series of exit lights can be wall mounted or ceiling mounted, is single or double face universal type. This range is strictly self contained luminaire, and does not come with the DALI monitoring option. Within the self-contained version, it has Auto test and Manual test option models.

AUTO Test

Auto-Test Option provides automatic testing of light fitting when used without DALI central monitoring option, and provides continuous monitoring of the unit and indicates service alert using dual-color LED lamp

The unit will automatically initiate a Self-Test and Self-Diagnostics test as follows:

- Verifies battery disconnection, charger failure, lamp failure and transformer
- failure at every 5 seconds.
- One minute self-testing every month.
- 30 minutes self-testing on the 6th month of the year after installation.
- 90 minutes self-testing on the 12th month of the year after installation.
- Automatically indicates lamp, battery and charger status by dual-color
- LED lamp.
- Factory preset - does not need field adjustment.



Main Features

- Compact and decorative design.
- LED self contained luminaire with manual test and AUTO test optional.
- Ni-MH battery.
- Single and double face universal.
- Replaceable pictogram design, including right arrow, left arrow, and no arrow pictograms in package.
- High luminance model optional.
- Low operation cost via low power consumption.
- Maintained and non-maintained operation changeable.
- Material of luminaire compliant with the glow wire test at temperature of 850C.
- RoHS compliance.

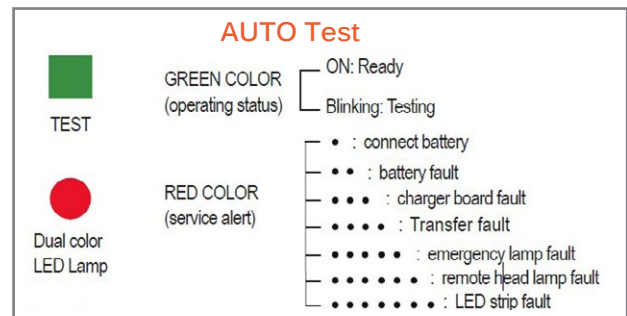



Manual Test

Tests are initiated manually, and can be initiated by the following action:

Press test button once	30 seconds test
Press test button twice (within 2 seconds)	3 minutes test
Press test button 3 times (within 2 seconds)	30 minutes test
Press test button 4 times (within 2 seconds)	1 hour or 3 hours test

Service Alert code for Manual Testing:

One blink ON/pause (4 seconds)	Battery is not connected
Two blink ON/pause (4 seconds)	Battery is shorted or Battery voltage drops below than acceptable value
Three blink ON/pause (4 seconds)	Charger board circuit fault
Four blink ON/pause (4 seconds)	Transfer fault
Five blink ON/pause (4 seconds)	Emergency lamp fault

TECHNICAL SPECIFICATION

Rated Power Supply	220-240VAC 50/60Hz
Central battery system (CBS) version available	DC176-254V input
Power consumption	Max. 5.6W
Charge time	24 hours
Discharge duration	1hour/3hours
Changeover voltage	144-187VAC
Test facility	Manual test and AUTO test
Viewing distance	24m
Operation	Maintained and Non-maintained
Mounting	Wall mounting and Ceiling mounting
LED	SMD 2835, CCT 6000K, CRI>70
Safe color of Pictogram	Pantone 336C or Pantone 348C optional
Luminance of white area on pictogram	Normal luminance 200cd/m2 High luminance 500cd/m2
Degree of protection	IP20
Insulation Class	Class II
Housing material	ABS
Ambient temperature	0C...+40C
Certification	TUV, CE, CB



DIMENSIONS (mm)

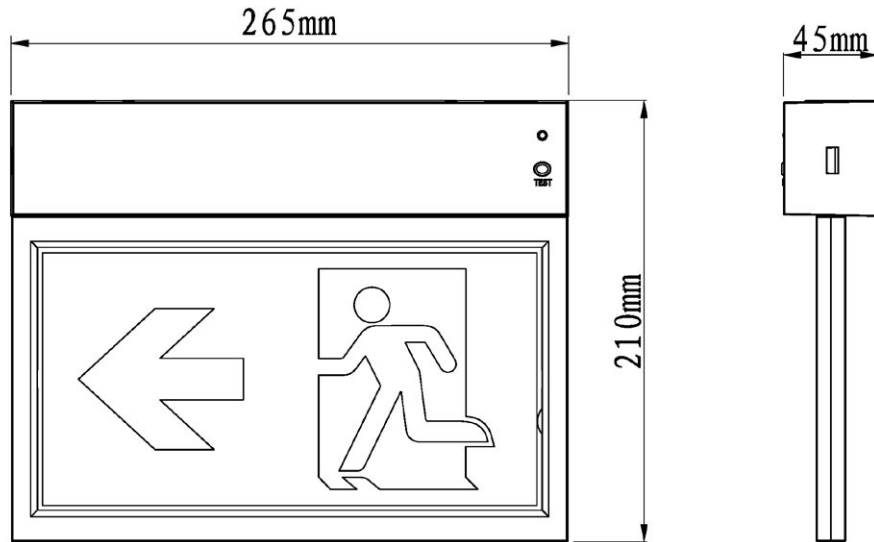

PICTOGRAM PACK



Arrow right 1pc



Without Arrow 1pc



Arrow left 1pc

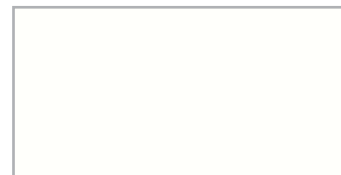

Blank 1pc

**MODEL LIST**

Part number	Alternative part number	Alternative part number	Discharge Duration	Power Consumption	Battery	LED
9108-1MH	ESA08/1H/MT/MH	Manual	1H	3.5W Max	Ni-Mh 3.6V 0.6Ah	SMD 3528 14PCS
9108-3MH	ESA08/3H/MT/MH	Manual	3H	3.5W Max	Ni-Mh 3.6V 0.6Ah	SMD 3528 14PCS
9108-1AH	ESA08/1H/AT/MH	Auto	1H	3.5W Max	Ni-Mh 3.6V 0.6Ah	SMD 3528 14PCS
9108-3AH	ESA08/3H/AT/MH	Auto	3H	3.5W Max	Ni-Mh 3.6V 0.6Ah	SMD 3528 14PCS

ORDER GUIDE

X-Y-Z ARE THE THREE ALPHABETS AFTER THE SERIES NUMBER OF THE MODEL

X		Y		Z	
Battery stand-by Duration		Type of test		Battery Type	
1	For 1 Hr	M	Manual testing	L	Lithium Iron Phosphate
3	For 3 Hrs	A	Auto Testing	C	Nickle cadmium
		D	DALI	H	Nickel metal Hydride